



FHT10

FULL HEIGHT TURNSTILE

- FHT10 is a single passage full height turnstile, 304 stainless steel body, which is especially suitable for reliably securing outdoor areas.
- This solid and high quality gates are usually use at places where need extreme high security and reliability, like jails, airports, stadiums, governments, private building, etc.
- The FHT10 features designed with standard relay signal, which can integrate easily to any kind of access control and fire systems through I/O (dry contact).
- Passing direction: uni-directional / bio-directional.
- In case of emergency, when power goes off both directions are free.

1 HIGH SECURITY

Full height turnstile is not able to crawl underneath and climb over to gain unauthorized access. Besides, the gate adopts high quality 304/306 stainless steel to replace ordinary steel.

2 EMERGENCY AND FIRE SAFETY

Arm rotor will automatically release for free passage during power failure. This is complying with fire safety requirements.

3 OUTDOOR INSTALLATION

Solid body is used 304 SS material, making the gate adapt to serve environment especially suffer rainstorm or under blazing sun when installed at outdoor.

4 SOLID DESIGN

The transverse bars joint at the middle of both sides, making the whole frame more solid and stable.



5 LOCKING SYSTEM

The locking mechanism prevents rotor from turning back, and only allows one person passing through at a time.

6 LED INDICATOR

LED indicators on the top and front display the status of passing, red cross means gate open, green arrow means gate closed.



Entry/Exit



Default

Multiple Operating Modes-optional

IC/ID card, key fob, QR/bar code, face / fingerprint / finger vein biometric recognition, push button, ESD, wireless remote control, insert coins / card / wristband, digit counter...

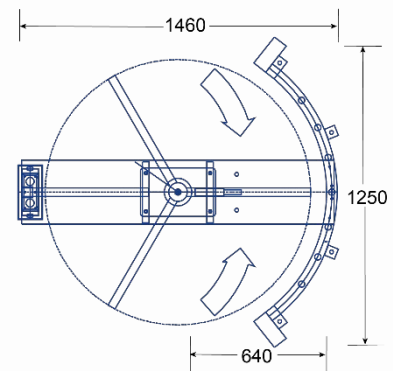
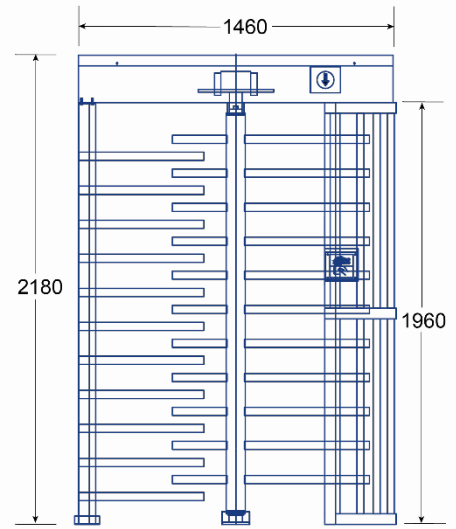

TECHINCAL SPECIFICATION

Material	304 Grade Stainless Steel
Dimension	1460(L) X 1250(W) X 2180(H)mm
Arm Rotor	3 sections (120° rotor)
Passage Width	640mm
Throughput	35 to 40 people per minute
Response Time	≤0.3S
Net Weight	150kg/pcs
Directional Mode	Uni-directional or bio-directional
Power Supply	AC220V/110V, 50/60Hz
Power Voltage	24V DC
Power Consumption	40W
MCBF	5 million
Operating Temperature	-15 °C - 60 °C
Operating Environment	Indoor or outdoor
Relative Humidity	≤ 95%
LED Indicators	Red cross means gate closed, green arrow means gate opened
Warranty	18 Months