



## AZ611

### SLIDING TURNSTILE

- Sliding turnstile has a solid cabinet with a sleek black tempered glass on top, which adds splendors to the any of installation environment.
- The body is made of brushed stainless steel which is robust, rigid, anti-rust, waterproof and durable.
- It is suitable for areas with general pedestrian traffic (e.g.: Office buildings, Gyms, Shopping malls, Schools, Government buildings, etc.).
- In case of emergency, when power goes off both directions are free.
- Passing direction: uni-directional / bio-directional.

## AZ611 Standard Passage Solutions



## AZ611 Multi Passage Solutions



# FEATURES

## 1 AESTHETICAL DESIGN

Sliding Turnstile AZ611 with a standard glass 600mm provides an artistic and high secure solution for access control at sites.

## 2 EMERGENCY AND FIRE SAFETY

The arms will automatically open during power failure. Speed gate also can be triggered to permanently open during emergency to facilitate fast evacuation. This is complying with fire safety requirements.

## 3 HIGH-END ATMOSPHERE

The top is covered black tempered glass, elegant with excellent performance, especially designed for high end places, e.g.: office buildings, gyms, shopping malls, schools, government buildings, etc.

## 4 FLEXIBLE SECURITY

The turnstile designed with consolidated and more durable mechanism, will not break even someone collide it, anti-collision and anti-kick function.

## 5 AUTO CLOSE TIMER

The arms will close automatically if there is no pedestrian passing or passenger delay to entry.

## 6 ALARM DETECTION

IR sensors detect unauthorized or abnormal access. Alarm buzzer function will be triggered when the user is passing thru without authorization, tail gaiting, illegal intrusion or incorrect direction.

## Multiple Operating Modes-optional

IC/ID card, key fob, QR/bar code, face / fingerprint / finger vein biometric recognition, push button, ESD, wireless remote control, insert coins / card / wristband, digit counter...

# DRAWINGS (dimensions in mm)

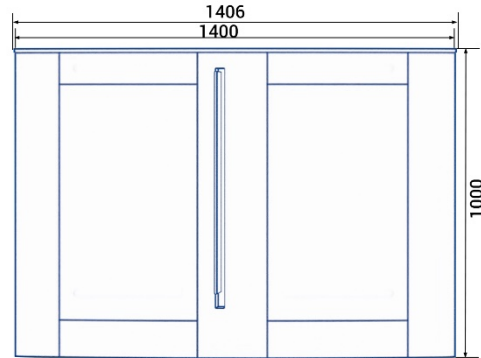
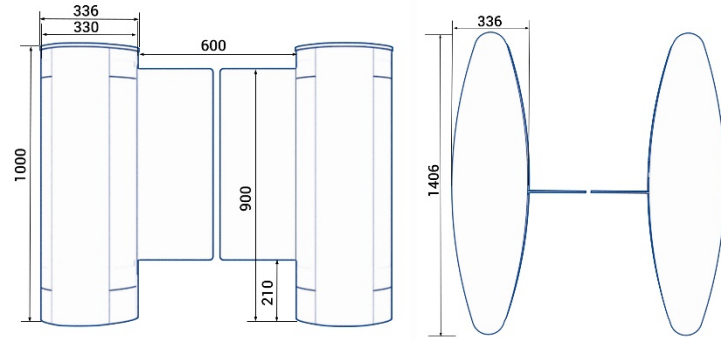

## TECHINICAL SPECIFICATION

Material	304 Grade stainless steel+ plexiglas arm + tempered glass on top
Cabinet Dimension	1406(L) X 330(W) X 1000(H)mm
Arm Material	Plexiglas-transparency
Passage Width	600mm standard lane
Throughput	35 to 40 people per minute
Response Time	≤0.5S
Net Weight	90kg/pcs single core 100kg/pcs double core
Directional Mode	Uni-directional or bio-directional
IR Sensor	6 pairs (standard)
Power Supply	AC220V/110V, 50/60Hz
Power Voltage	24V DC
Power Consumption	40W
MCBF	12 million
Operating Temperature	-15 °C - 60 °C
Operating Environment	Indoor or outdoor (need with shelter)
Relative Humidity	≤ 95%
Warranty	36 Months